

LUBRICATION ORDER

LO 5-4320-251-12

23 May 1978 (Supersedes LO 5.4320-251-12, 5 March 1971)

PUMP, RECIPROCATING, POWER DRIVEN DIAPHRAGM, GASOLINE
ENGINE DRIVEN, WHEEL MOUNTED, 100 GPM
 (GORMAN-RUPP MODEL 4D2A016)

Reference: LO 5-2805-257-12, and C9100-IL

Intervals and related task-hour times are based on normal hours of operation. The task-hour time specified is the time you need to do all the services prescribed for a particular interval. Change the interval if your lubricants are contaminated or if you are operating the equipment under adverse operating conditions, including longer-than-usual operating hours. You may extend the interval during periods of low activity, but you must take adequate preservation precautions.

*The time specified is the time required to perform all services at the particular interval.

Clean fittings before lubricating. Relubricate all areas exposed to water after amphibious operation, Lubricate points

indicated by dotted arrow shaft on both sides of equipment, Clean parts with SOLVENT, dry cleaning, or with OIL, fuel, diesel. Dry before lubricating. Drain crankcase when HOT. Fill and check level. The lowest level of maintenance authorized to lubricate a point is indicated by one of the following: (C) Operator/crew; or (O) Organizational Maintenance.

You can help improve this publication. If you find any mistake or if you know of a way to improve the procedures, please let us know. Your letter or DA Form 2028 (Recommended Changes to Publications and Blank Forms) should be mailed directly to: Commander, U. S. Army Troop Support & Aviation Materiel Readiness Command, ATTN: DRSTS-MTPS, 4300 Goodfellow Blvd. St. Louis, MO 63120, A reply will be furnished to you.

* TOTAL TASK-HR		* TOTAL TASK-HR	
INTERVAL	TASK-HR	INTERVAL	TASK-HR
10	0.3	100	0.2

FOLD

FOLD

LUBRICANT ● INTERVAL

INTERVAL ● LUBRICANT

For Engine Lubrication
 See L05-2805-257-12

Gearcase Drain Plug
 (O) (Drain and refill)

Wheels GAA 500
 (C) (Sparingly)

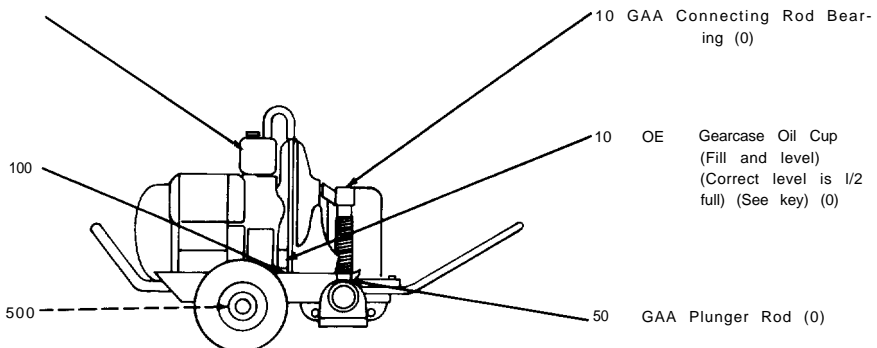

- KEY -

LUBRICANTS	REFILL CAPACITY (APP)	EXPECTED TEMPERATURES			INTERVALS
		Above +32° F Above 0°C	+40°F to -10° F + 5°C to -23°C	0°F to -65°F -18°C to -50°C	
(MIL-L-2104) OIL, Engine, Heavy Duty Oil Can Points Gear Case	1 qt (0.95L)	OE 30	OEA/APG-PD-1		Intervals given are in hours of normal operation
OEA/APG-PD-1 OIL, Engine, Subzero GAA GREASE, Automotive [MIL-G-10924], and . Artillery					

NOTES:

1. FOR OPERATION OF EQUIPMENT IN PROTRACTED COLD TEMPERATURES BELOW -10°F (-23°C). Remove lubricants prescribed in the key for temperatures above -100F (-23°C). Clean parts with SOLVENT, dry-cleaning. Relubricate with lubricants specified in the key for temperatures below -10°F (-23°C).

Copy of this Lubrication Order will remain with the equipment at all times; instructions contained herein are mandatory.

BY ORDER OF THE SECRETARY OF THE ARMY:
BERNARD W. ROGERS
General, United States ARMY
Chief of Staff

OFFICIAL:
J. C. PENNINGTON
Brigadier General, United States Army
The Adjutant General

DISTRIBUTION: To be distributed in accordance with DA Form 12-25A, Operator maintenance requirements for Petroleum Distribution.

FOLD

FOLD